



FilterBlueMaxi

Housings for filter cartridges

Model: FilterBlue Maxi FBLM

FilterBlueMaxi housing and filtration cartridges

The market is now saturated with *standard*, poor quality filter cartridges of dubious origin, produced by companies with limited expertise and marketed to resellers, water treatment plant manufacturers and end-users at very low prices.

In particular, filter cartridges are marketed to retailers, installers, and end users at lower prices, which consistently take customers away from water treatment plant manufacturers by preventing them from getting a fair economic return from selling filter cartridges on their systems.

Everblue has been studying, designing and manufacturing housings filter cartridge and related filter elements in Italy since 2001 using top-quality European materials. High quality standards respected and guaranteed at all stages ensure innovative and reliable products.

FilterBlueMaxi housings and filter cartridges represent, technically and economically, the best solution available on the market for the construction of high flow filtration systems as pretreatment of reverse osmosis plants.

Their uniqueness represents a natural trade protection from the attacks of standard products and their undisputable quality always ensures better performance than any other alternative.



very high flow rate
easy cartridge replacement



FilterBlueMaxi housings

FilterBlueMaxi housings are produced in four different sizes:

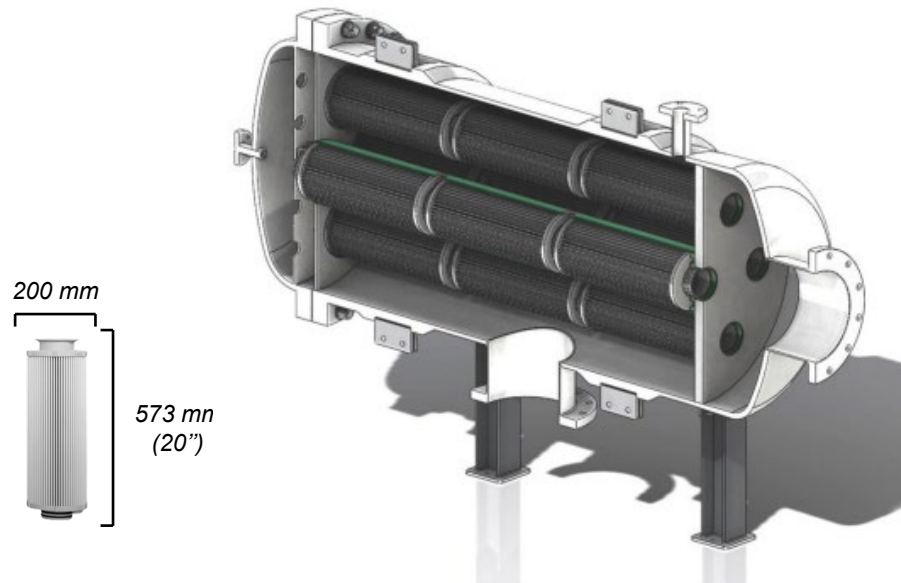

FilterBlueMaxi 12x20"
Contains 12 cartridges of 20"
Flow rate up to 216 m³/h

FilterBlueMaxi 39x20"
Contains 39 cartridges of 20"
Flow rate up to 702 m³/h

FilterBlueMaxi 21x20"
Contains 21 cartridges of 20"
Flow rate up to 378 m³/h

FilterBlueMaxi 57x20"
Contains 57 cartridges of 20"
Flow rate up to 1026 m³/h

FilterBlueMaxi housings guarantee:



High flow

Big sizes enough to guarantee flow rates from 216 m³/h to 1026 m³/h, thanks to filtering elements of the highest quality



High pressure resistance

Possibility to operate up to 6 bar



Absolute corrosion resistance

Guarantee of duration in the filtration also of sea waters

Why choose FilterBlueMaxi?

Uniqueness

FilterBlueMaxi housings are **unique** products because:

- They are the combination of the best technologies currently available on the market.
- They are made to be fitted 3 types of cartridges (depth, pleated and washable).

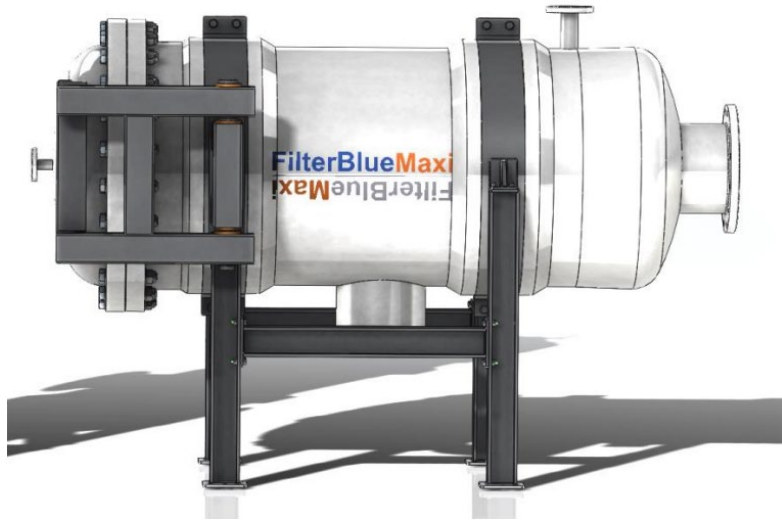

Simplicity

FilterBlueMaxi housings are **easy** to use:

- A single operator opens and closes the FilterBlueMaxi container manually in a few minutes, thanks to the davit that ensures easy opening of the lid.
- The FilterBlueMaxi filter cartridges insert and pull out quickly by attaching quickly to each other thanks to the bayonet mount.



FilterBlueMaxi filtration cartridges

FilterBlueMaxi filtration cartridges are made in three different version to meet all filtration requirements:

Depth filtration cartridges

N95BL

Polypropylene Melt Blown



High filter volume

High loading capacity of particles with heterogeneous size

Pleated filtration cartridges

PP95BL

Polypropylene Pleated



High filter surface

High loading capacity of particles with homogeneous size

Washable filtration cartridges

TPL95BL

Pleated Polyester Net
TekBlue



Washable

High particle loading capacity with possibility of reuse



FilterBlueMaxi filtration cartridges guarantee:



Long life

The high filtering surface/volume allows a significant dirt holding capacity that is equivalent to a long service life and a consequent reduction in operating costs



High flow

The large surface/volume allows high flow rates to be treated using filter housings and batteries having small footprints



High efficiency

The high particle removal efficiency of the filter septa enables the production of quality water for all usage needs

FilterBlueMaxi N95BL depth filtration cartridges

Depth filtration cartridges

N95BL
Polypropylene Melt Blown



double gradient

High filter volume
High loading capacity of particles with heterogeneous size

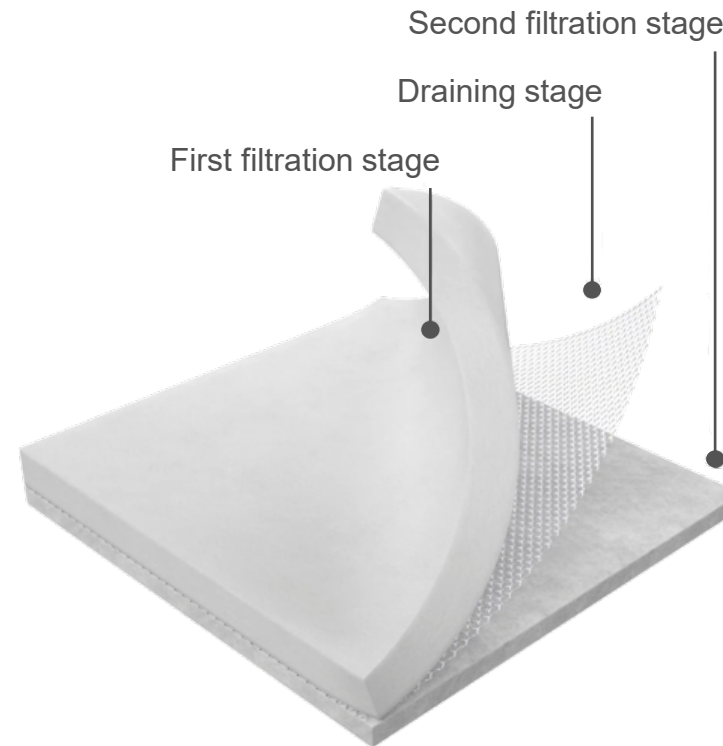

The **FilterBlueMaxi N95BL** cartridges are made of extruded polypropylene with internal support and rigid molded polypropylene terminals.

The **FilterBlueMaxi N95BL** cartridges guarantee very high load capacity thanks to the **double gradient** double filtering layer.

The first layer accumulates the coarsest particles while the second layer performs the final finishing by retaining the smaller particles.

These cartridges are ideal for treating non-refined water with high presence of suspended solids (up to a maximum of 1 ppm TSS) with heterogeneous particle distribution.

FilterBlueMaxi N95BL cartridges are produced in the following filtration grades: 1-10 μ , 5-20 μ , 20-50 μ , 50-90 μ with 95% removal efficiency (99.98% absolute on request).

FilterBlueMaxi PP95BL pleated filtration cartridges

Pleated filtration cartridges

PP95BL

Polypropylene Pleated



5 Layers

High filter surface

High loading capacity of particles with homogeneous size

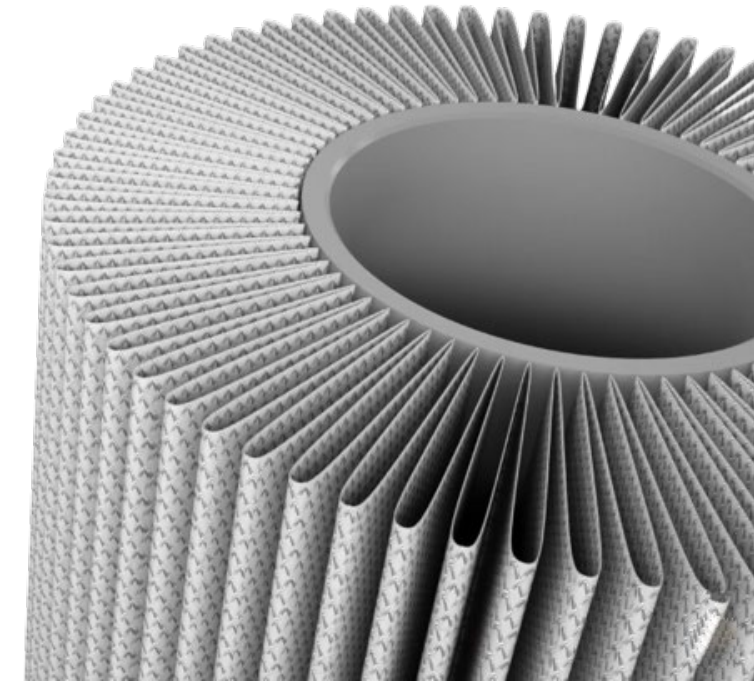
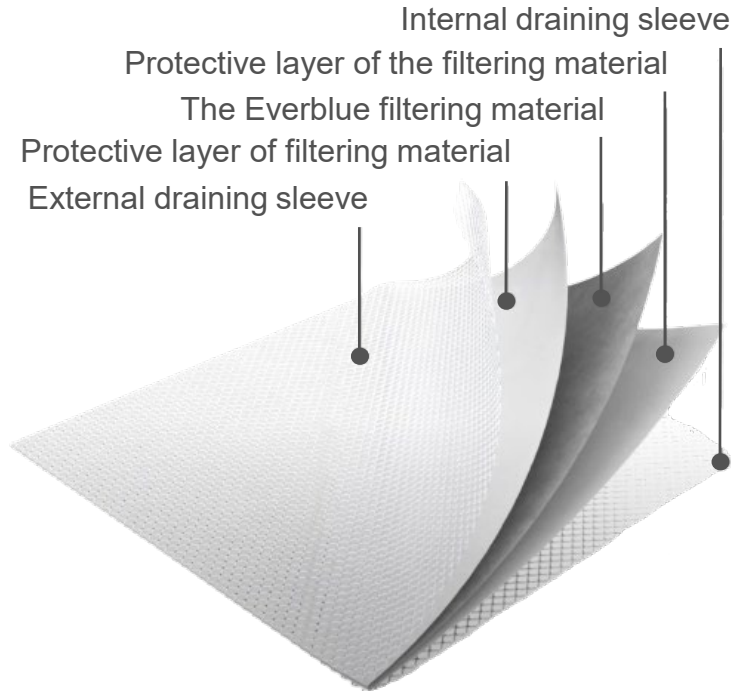

FilterBlueMaxi PP95BL cartridges consist of: 3-layer polypropylene filtering septum supported by an external PP drainage net and an internal PP drainage net (**5 Layers** filtering system); internal support and moulded rigid polypropylene terminals. The external drainage net of the **5 Layers** filter system prevents the crease from closing due to the increase in pressure due to the dirty filter material, always ensuring the constant outflow of filtered water towards the internal support of the cartridge.

FilterBlueMaxi PP95BL cartridges, thanks to the special filter system **5 Layers**, guarantee a longer life compared to the normal filter cartridges on the market having the same surface.

These cartridges are ideal for the final finishing of water containing homogeneous particle sizes (up to a maximum of 1 ppm TSS).

FilterBlueMaxi PP95BL cartridges are produced in the following filtration grades: 1, 5, 10, 20, 50 μ with 95% removal efficiency (99.98% absolute on request).



everblue.it

FilterBlueMaxi TPL95BL washable filtration cartridges

Washable filtration cartridges

TPL95BL
Pleated Polyester Net
TekBlue



500 CLEANING GUARANTEED



Washable

High particle loading capacity with possibility of reuse



Rigid polypropylene structure
filstar inside
PATENTED

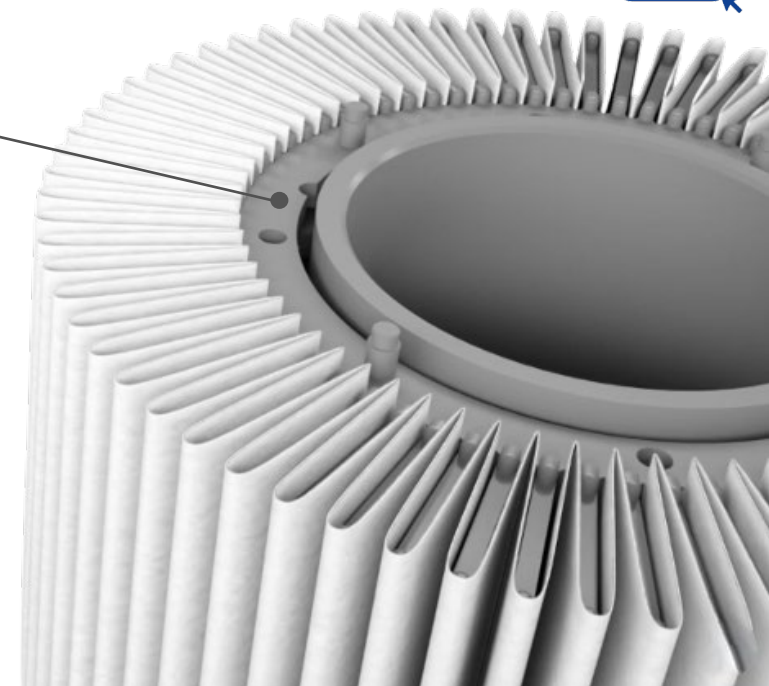

The **FilterBlueMaxi TPL95BL** cartridges consist of: moulded rigid internal support, moulded rigid polypropylene terminals and **TekBlue** pleated polyester mesh filtering panel coupled to a PP drainage net. The two nets are always kept perfectly open and in place by a special rigid polypropylene structure: the system **filstar** inside

The system **filstar** inside prevents the closing of the fold due to the increase in pressure as a result of the dirty filter material, always ensuring the constant outflow of filtered water to the inside of the cartridge. Also the rigidity of the folds guaranteed by system **filstar** inside allows easy and effective washability even with low pressure water jets (suggested pressure 2 bar – max 3 bar).

FilterBlueMaxi TPL95BL cartridges, with patented system **filstar** inside and **TekBlue** filter net, **are guaranteed to be washed at least 500 times**, thus allowing a very high cost savings.

These cartridges are ideal for the filtration of water that has a high presence of suspended solids (up to a maximum of 1 ppm TSS) with a heterogeneous distribution of particles.

FilterBlueMaxi TPL95BL cartridges are produced in the following filtration grades: 20, 50 µ with 95% removal efficiency.

More Info



Data Sheet
FilterBlueMaxi



Video
FilterBlueMaxi



Case History
FilterBlueMaxi

Company authorized to the use of the brand



Contact Us



Everblue

Via Alberto Zanrè, 16 - Loc. Gotra 43051 Albareto (PR)

www.everblue.it

[+3905251920100](tel:+3905251920100)

info@everblue.it

