







# FilMax

**Backwashable self-cleaning filters**  
**Model: FilMax FMX4000**

# Backwashable self-cleaning filters FilMax FMX4000

A self-cleaning filter is a type of filter specially designed to remove all suspended solids in surface waters (rivers, lakes, seas), wells and spring waters while automatically removing suspended solids inside the filter and guaranteeing:

-  **Time saving**  
Eliminates or reduces the time needed to replace cartridges and filtering bags
-  **Cost saving**  
Eliminates or reduces the use of cartridges and filtering bags
-  **Reduction of investment costs**  
Self-cleaning filters are much cheaper than classical sand filters
-  **Reduced installation footprint**  
Self-cleaning filters take up less space compared to classical sand filters



The backwashable self-cleaning filters manufactured by Everblue, denominated **FilMax FMX4000**, are used to remove particles with diameter between 800 and 50 micron inside fresh, brackish and sea water in quantities that don't exceed 100 ppm of TSS (Total Suspended Solids).

Depending on the applications, the functional limit parameters can be exceeded after verification and subsequent authorization by Everblue's technicians

The peculiarity of Everblue backwashable self-cleaning filters is the ability, through a process called "regeneration", to rapidly clean themselves in complete autonomy using a very limited quantity of water.



*the solutions  
technologically  
more advanced for the  
filtration  
with self-cleaning filters*

# Backwashable self-cleaning filters FilMax FMX4000

FilMax FMX4000 backwashable self-cleaning filter are produced in different sizes:

The main features of FilMax FMX4000 backwashable self-cleaning filter are:



**FilMax FMX4000 1x13"**  
Contains 1 cartridge of 13"  
Flow rate up to 18 m<sup>3</sup>/h



**FilMax FMX4000 1x20"**  
Contains 1 cartridge of 20"  
Flow rate up to 27 m<sup>3</sup>/h



## High flow

*Products with lengths (1x13" e 1x20"), diameters(6") and connections (2" - 3") such as to ensure flow rates from 18 m<sup>3</sup>/h to 27 m<sup>3</sup>/h*



## High pressure resistance

*Possibility to operate up to 10 bar*



## Absolute resistance to corrosion

*Durability guarantee in seawater filtration*

# Perché scegliere FilMax FMX4000: la struttura

Backwashable self-cleaning filter **FilMax FMX4000** are made of 3 main parts:

## 1 CARTRIDGES

The filter basket is the “operational” part of the filter, it is made entirely of plastic material (PVC) inside which there are two polypropylene drainage nets and a polyester filter net; this allows you to make the most of the entire filter surface of the basket. The filter basket retains water particles larger than 50 µm (0,05 mm) with a high efficiency of 90%.

## 2 FILTER BODY

Made of polyamide (PA) is perfectly compatible with all types of water. The filter body, together with the filter head, contains the filter element. The filter body ensures a perfect pressure seal.

## 3 FILTER CAP

Made of polyamide (PA) is perfectly compatible with all types of water. The filter head, together with the filter body, contains the filter element.



# FilMax FMX4000 operation: work

The water to be filtered enters through the inlet of the filter (1). It then filters from the internal part to the external part of the backwashable filter cartridge (3).

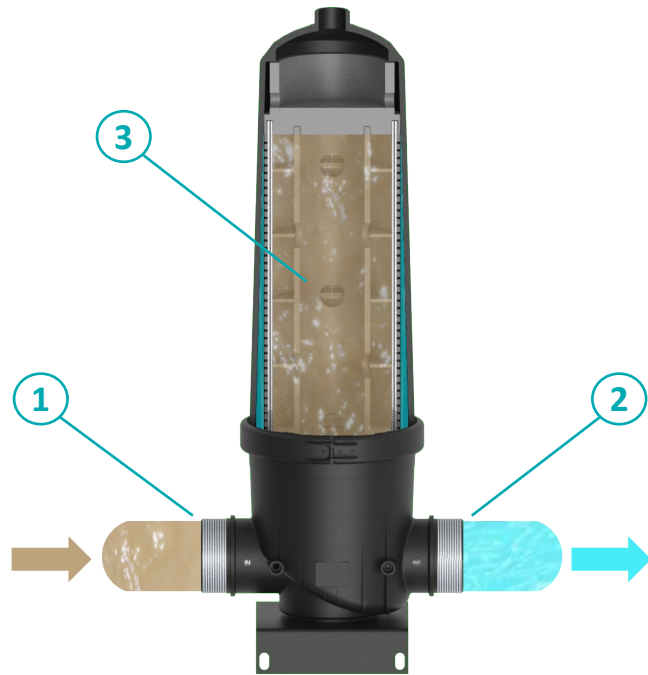

Foreign particles and suspended solids larger than the filtration degree of the cartridge are retained by the meshes of the filter cartridge net and accumulate progressively on it. The filtered water then comes out from the filter outlet (2).

The washable cartridge (3) consists of a micro-woven PVC basket supporting 3 different nets that allow effective and durable filtration.

- Polypropylene drainage net (placed between the PVC basket and the polyester filter net).
- Polyester filter net (carries out the filtration process)
- Spacer net (protects the filter net and maintains the correct distance between the filter net and the filter nozzle)

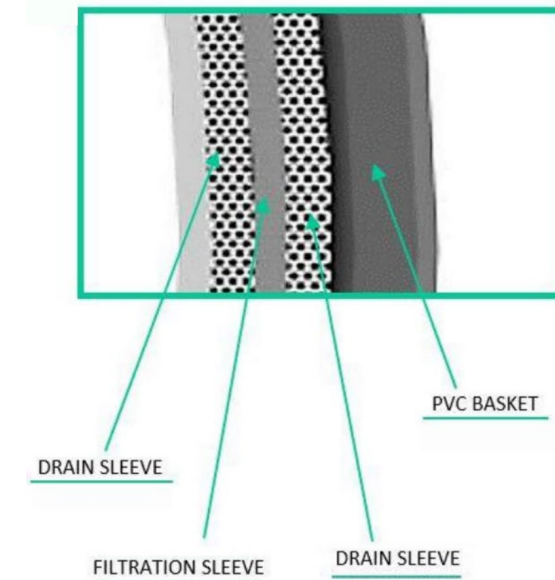

## FilMax FMX4000 operation: backwash

The foreign particles and the suspended solids retained on the surface of the backwashable filter cartridge (3) progressively occlude the meshes of the net, increasing the pressure drop. Thus, a pressure difference ( $\Delta P$ ) will begin to exist between the inlet pressure gauge and the outlet pressure gauge. At a set value of  $\Delta P$  (variable between 0.3 ÷ 1 Bar) it is necessary to start the backwash cycle.

During this cycle, the backwash water enters through the filter outlet (2). The flow of this water is distributed equally on the outside of the backwashable cartridge (3), then crossing it from the outside to the inside. The backwash water then comes out from the filter inlet (1).

This process causes foreign particles and suspended solids to detach from the surface of the backwash filter cartridge (3) and to be conveyed towards the backwash drain. The duration of this operation must be at least 10 seconds, at the flow rate and backwash pressure indicated in the technical data sheet of the backwashable filter. In any case, the effective duration of the backwash must be extended by a sufficient time to convey the backwash drain all the volume of water contained inside the pipeline between the filter outlet (2) and the exhaust valve.

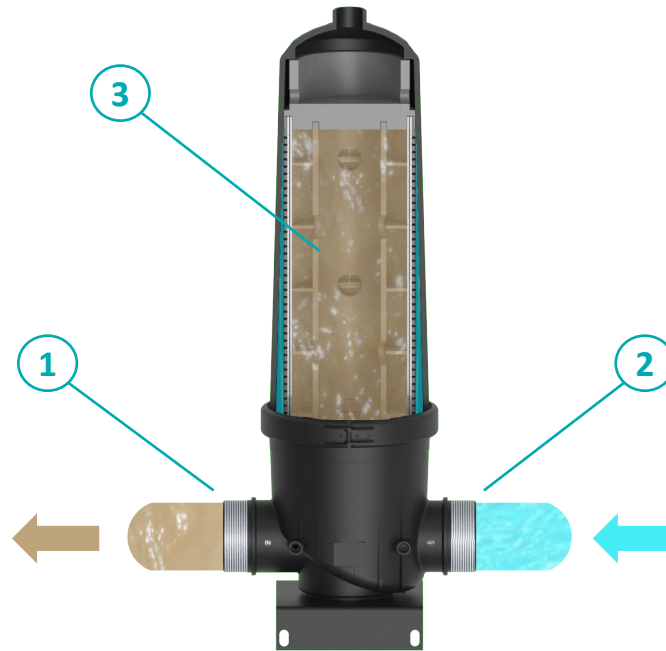

## FilMax FMX4000 operation: rinsing

In order to avoid subsequent contamination of the filtered water downstream of the filter, it is always better to provide a rinsing phase.

In this, the water to be filtered enters through the inlet of the filter (1). It is filtered by the backwashable filter cartridge (3) in the manner already described above. The water then exits from the filter outlet (2).

The rinsing duration must be performed at the flow rate and operating pressure of the backwashable filter. In any case, the actual duration of the described operation must be extended by a sufficient time to convey to the drain all the volume of water contained inside the pipe between the filter inlet (1) and the exhaust valve.

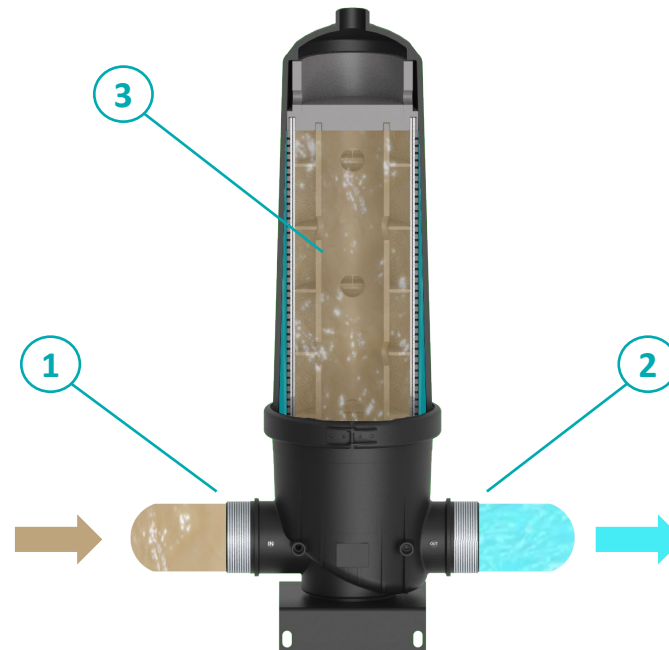

## Why choose FilMax FMX4000: easy maintenance

- A** Open the clamping flange of the **FilMax FMX4000** enclosure:



- B** Completely remove the lid of the container **FilMax FMX4000**:



- C** Insert the cartridge into the body of the **FilMax FMX4000** container:



- D** Reinsert the lid into the **FilMax FMX4000** container and make sure to close the clamping flange:



*To remove the cartridge from the backwashable self-cleaning filter **FilMax FMX4000** proceed in reverse with respect to installation. Inserting and removing cartridges is very easy and takes only couple of minutes.*

# Why choose FilMax FMX4000

## Uniqueness

Backwashable self-cleaning filters **FilMax FMX4000** are **unique** products because:

- They are the combination of the best technologies currently available on the market.
- They are produced in 2 different lengths that are easily assembled into batteries with special assembly kits (frame and manifolds).
- They are designed to accommodate a multi-layer cartridge that allows optimal filtration



## Simplicity

Backwashable self-cleaning filters **FilMax FMX4000** are **easy** to use:

- A single operator opens and closes the **FilMax FMX4000** container manually in a few minutes.



# Why choose FilMax FMX4000: modularity

Backwashable self-cleaning filters **FilMax FMX4000** allow the construction of ideal **modular** batteries to meet all flow rates at reduced costs.



**FilMax FMX4000**  
FMX4000-2RS  
Flow rate up to 54 m<sup>3</sup>/h



**FilMax FMX4000**  
FMX4000-3RS  
Flow rate up to 81 m<sup>3</sup>/h



**FilMax FMX4000**  
FMX4000-4RS  
Flow rate up to 108 m<sup>3</sup>/h

## More info



**Data sheet**  
**FMX4000**



**Case History**



**Technical Courses**



# Contact Us



Everblue

Via Alberto Zanrè, 16 - Loc. Gotra 43051 Albareto (PR)

[www.everblue.it](http://www.everblue.it)

[+3905251920100](tel:+3905251920100)

[info@everblue.it](mailto:info@everblue.it)

