







FilMax

Self-cleaning filters
Model: FilMax FMX2000A

Self-cleaning filter with suction nozzles FilMax FMX2000A

A self-cleaning filter is a type of filter specially designed to remove all suspended solids in surface waters (rivers, lakes, seas), wells and spring waters while automatically removing suspended solids inside the filter and guaranteeing:

-  **Time saving**
Eliminates or reduces the time needed to replace cartridges and filtering bags
-  **Cost saving**
Eliminates or reduces the use of cartridges and filtering bags
-  **Reduction of investment costs**
Self-cleaning filters are much cheaper than classical sand filters
-  **Reduced installation footprint**
Self-cleaning filters take up less space compared to classical sand filters



The automatic self-cleaning filters with suction nozzles manufactured by Everblue, denominated **FilMax FMX2000A**, are used to remove particles with diameter between 800 and 25 micron inside fresh, brackish and sea water in quantities that don't exceed 100 ppm of TSS (Total Suspended Solids).

Depending on the applications, the functional limit parameters can be exceeded after verification and subsequent authorization by Everblue's technicians

The peculiarity of Everblue automatic self-cleaning filters is the ability, through a process called "regeneration", to rapidly clean themselves in complete autonomy using a very limited quantity of water.



versatile and efficient

Self-cleaning filter FilMax FMX2000A

The dimensions of FilMax FMX2000A self-cleaning filters are:

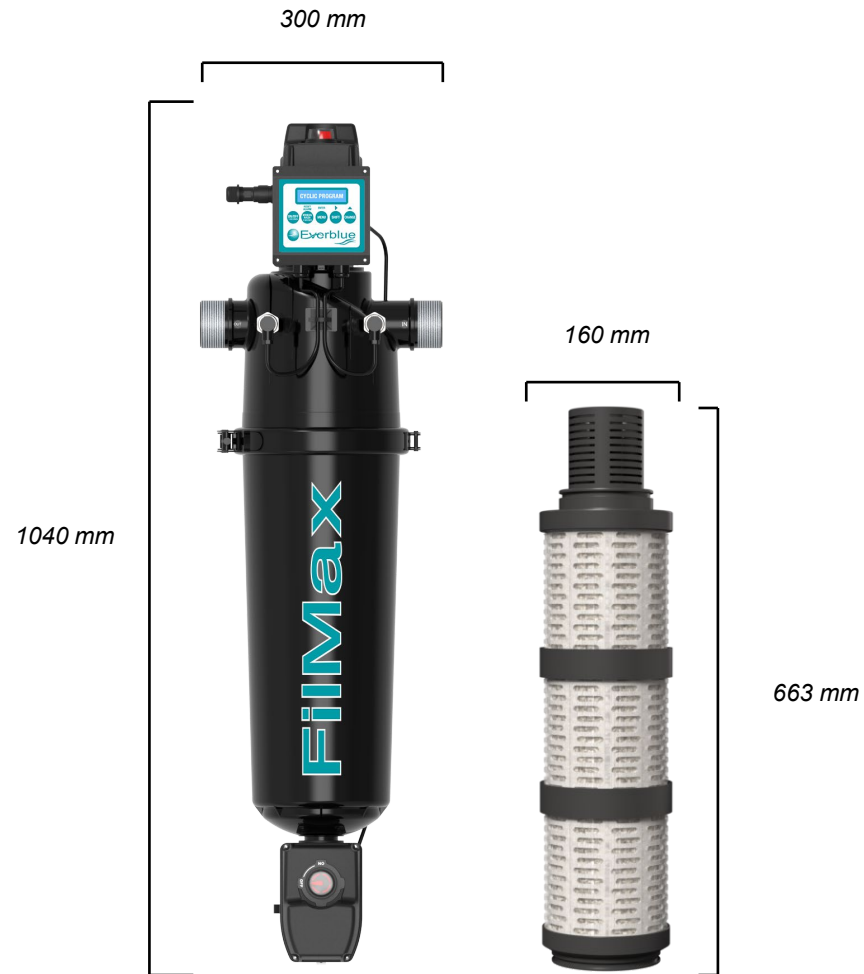

The main features of FilMax FMX2000A self-cleaning filters are:



High flow rate

Hybrid filter body, manufactured with 2" connections to guarantee flow rates of 18 m³/h



High pressure resistance

Capable of operating at up to 6 bar



Absolute resistance to corrosion

Guaranteed durability in the filtration of all types of water, particularly sea water

Why choose FilMax FMX2000A: simplicity

FilMax FMX2000A self-cleaning filters are simple because they are made of 3 main parts:

1 FILTER BODY

Made of polyamide (PA), it is perfectly compatible with all types of water. The filter body contains all the components necessary for the filtration process, also ensuring a perfect seal at pressure (6 bar).

2 SELF-CLEANING BASKET

Entirely made of plastic material (PVC and PP) they are the elements necessary for filtration and for the “regeneration” system. Inside, a rotating system in which the basic elements are the suction nozzles, allows the cartridge to continue filtering even during the regeneration and cleaning process of the net.

3 FILTER HEAD

Filter head constitutes the soul of the filter, which is what makes it a completely autonomous and automatic product in all respects. The control panel allows constant monitoring of operation and allows the management of all the filter functions.



Why choose FilMax FMX2000A: versatility

The FilMax FMX2000A self-cleaning filter can be installed vertically in four different positions depending on requirements:



*Filter body in standard vertical position
and control unit in standard vertical position*



*Filter body in standard vertical position
and control unit rotated 180° horizontally*



*Filter body rotated 180° vertically
and control unit in standard vertical position*



*Filter body rotated 180° vertically
and control unit rotated 180° horizontally*

Why choose FilMax FMX2000A: easy maintenance

The installation of **FilMax FMX2000A** self-cleaning filter is very simple and takes only a couple of minutes.

- 1 Open the clamping flange that holds the head together with the body of the **FilMax FMX2000A** filter:



- 2 You can then remove **FilMax FMX2000A** filter body:



- 3 Grasp and pull the self-cleaning basket out of the **FilMax FMX2000A** filter head:

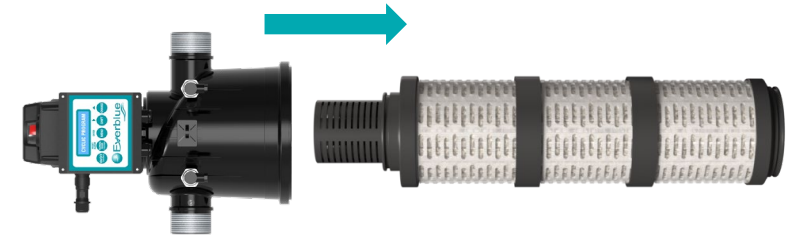

- 4 Reinsert the self-cleaning basket followed by the body, insert the flange and close it to reassemble the **FilMax FMX2000A** filter:



FilMax FMX2000A: functioning

Water enters the filter (1) it goes through the tube (2) from the outside to the inside, then it is distributed inside the filtering mesh (3), which retains all suspended solids larger or equal to the degree of filtration installed. The filtered water leaves the filter (4).

Before the self-cleaning filter you must install a pre-filtration filtering basket to block all solids larger than 3 mm that could obstruct the suction nozzles compromising the washing effectiveness and damaging the filtering net, compromising the effectiveness of the filter and its integrity.

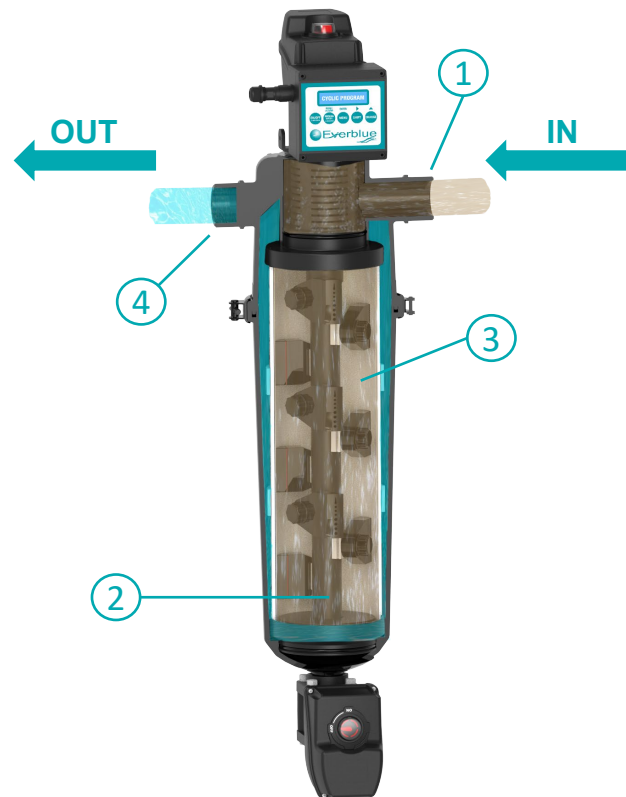

The self-cleaning basket (3) is made of a micro-fessured PVC basket that supports 3 different nets that allow effective and long-lasting filtration:

- Draining polypropylene net (placed between the PVC basket and the polyester filtering net)
- Polyester filtering net (carries out the filtration process)
- Separating net (protects the filtering net and maintains the correct distance between the filtering net and the filtering nozzle)

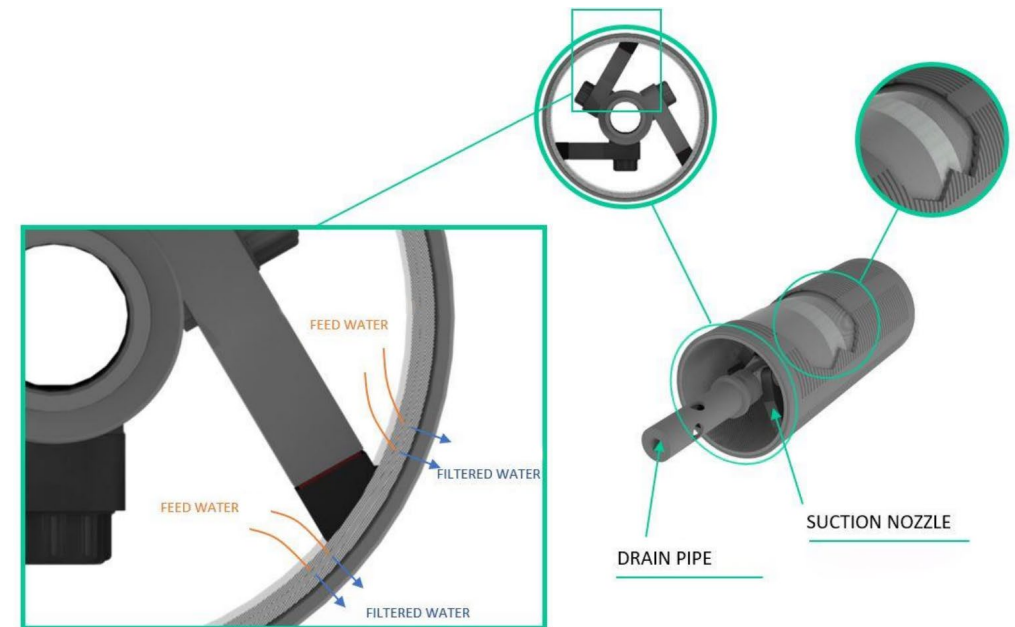

FilMax FMX2000A: regeneration

The continuous settling of suspended solids inside the self-cleaning basket (1) form an impediment to the passage of water, which is manifested in a pressure difference (ΔP).

At a preset value of ΔP (range 0,3÷1 Bar) the cartridge cleaning cycle will start automatically. This operation begins with a signal that opens the drain valve and rotates the scanner (3) through the electric motor.

Dirt is sucked up by the nozzles (3) and evacuated through the drain valve. The cleaning cycle lasts approximately 10 seconds.

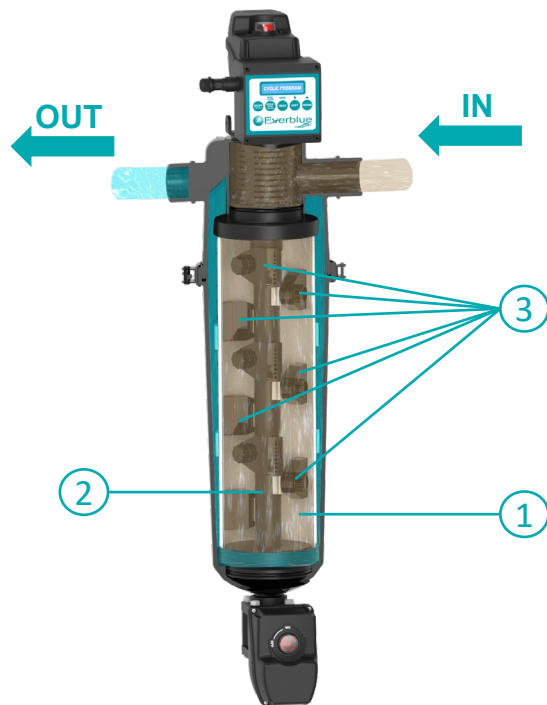

Suction through the suction nozzles is possible thanks to the differential pressure on the surface of the suction nozzles and the filtering basket.

The suction nozzles are connected, through the related supports, to the discharge pipe located inside the self-cleaning filter that is also connected to the discharge valve. When the discharge valve, connected to the cockpit or a pipe with no pressure opens, it generates a differential pressure compared to the inside of the filter (pressurized) creating the sucking effect on the nozzles. To create the suction the filter need 1 bar of pressure only and can guarantee high energy savings.

FilMax FMX2000A allows continuous flow even during the regeneration phase, while maintaining its productivity and reducing the waste of water to a minimum.

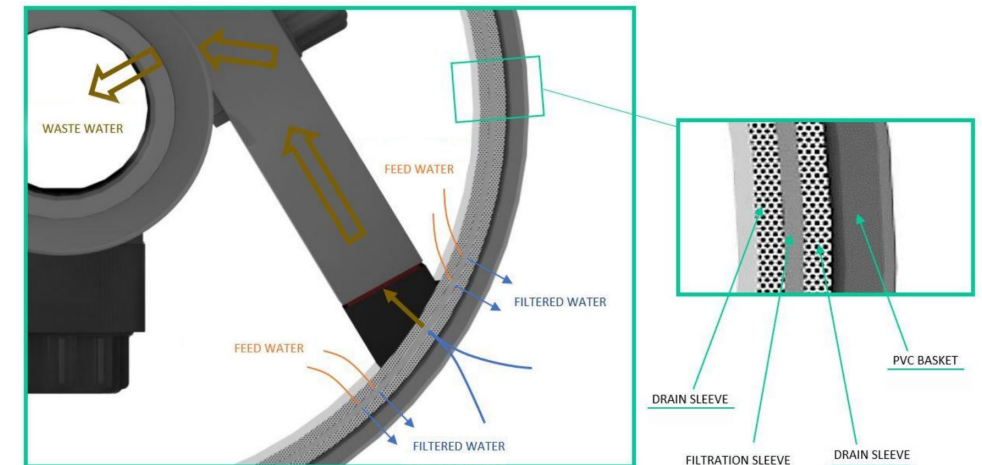

More Info



Datasheet
FMX2000A



Contact Us



Everblue

Via Alberto Zanrè, 16 - Loc. Gotra 43051 Albareto (PR)

www.everblue.it

[+3905251920100](tel:+3905251920100)

info@everblue.it

