

*: DISTANZA MINIMA PER MANUTENZIONE
 *: MINIMUM DISTANCE FOR MAINTENANCE

Dimensioni in mm.	Finitura superfici in Ra μ m	TOLLERANZE GENERALI : UNI-EN 22768-mK UNI-EN 22768-c	RAGGI NON QUOTATI: R=0.3 SMUSSI NON QUOTATI: 0.3x45°
MATERIALE :	GREZZO : -	FINITURA SUPERFICIALE : -	DESCRIZIONE
DISEGNATO DA : Tecnico		APPROVATO DA : -	CODICE
DATA 14/11/2025		DATA : -	REV.
BASKETBLACK FBBS		FBBS316L200FF__M__	
		REV.	DESCRIZIONE REVISIONE
RIPRODUZIONE PROIBITA - TUTTI I DIRITTI RISERVATI AI SENSI DELLA LEGGE		DATA REV.	REVISIONATO DA:
		SCALA	
		1:5	

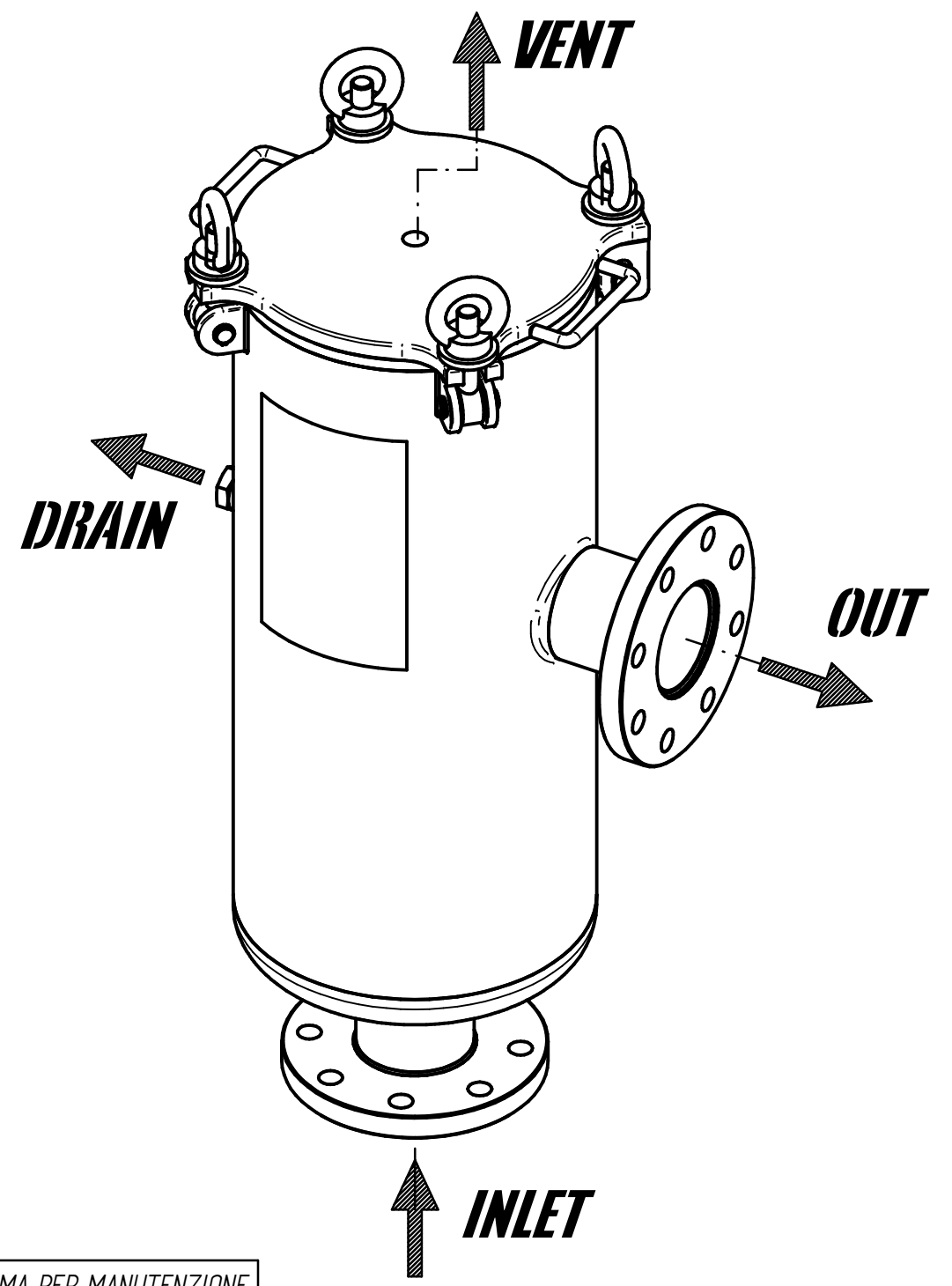
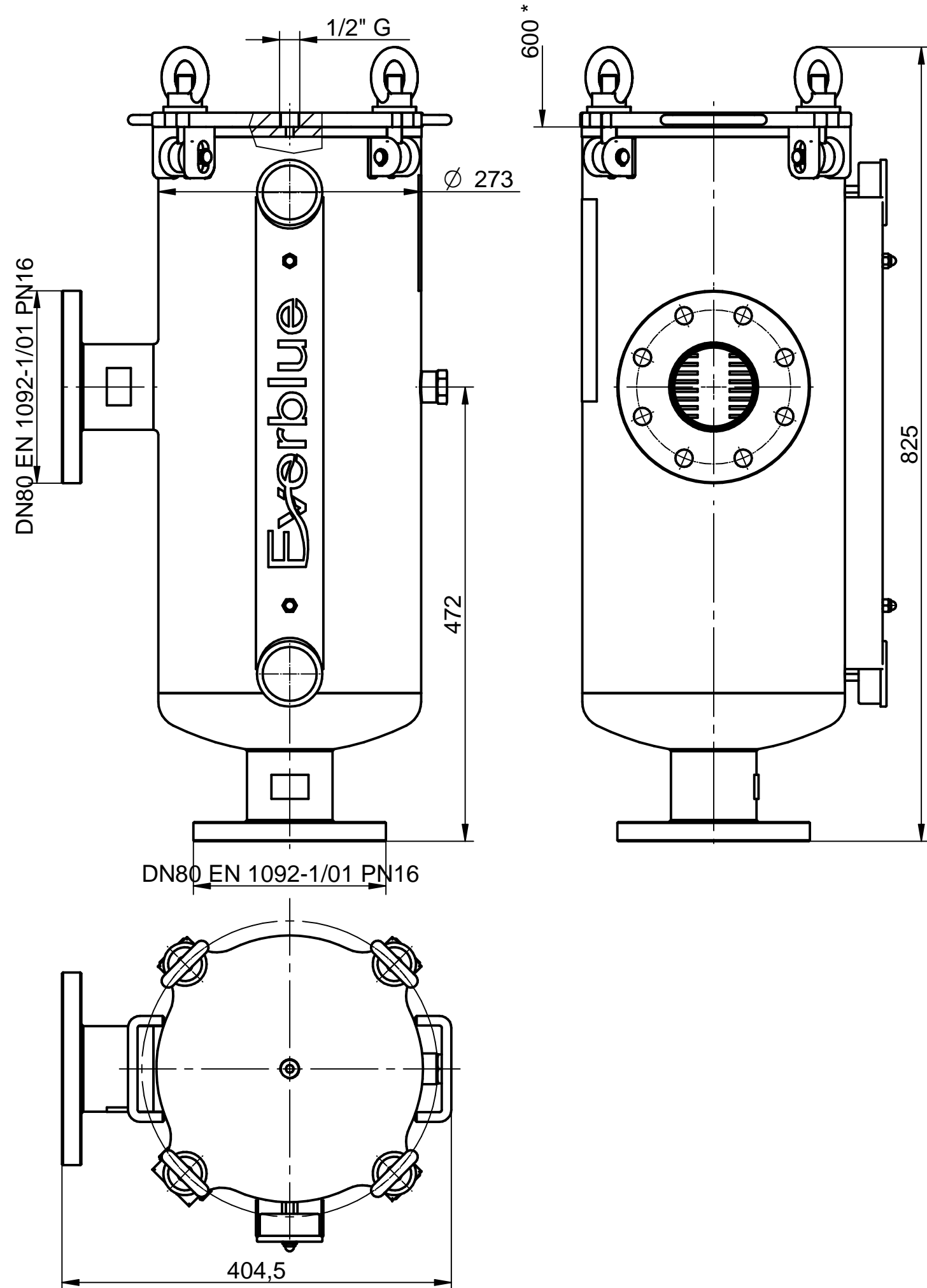

*: DISTANZA MINIMA PER MANUTENZIONE
 *: MINIMUM DISTANCE FOR MAINTENANCE

Dimensioni in mm.	Finitura superfici in Ra μ m	TOLLERANZE GENERALI : UNI-EN 22768-mK UNI-EN 22768-c	RAGGI NON QUOTATI: R=0.3 SMUSSI NON QUOTATI: 0.3x45°
MATERIALE :	DISEGNATO DA :		APPROVATO DA :
GREZZO : -	Tecnico		-
FINITURA SUPERFICIALE : -	DATA 14/11/2025		DATA : -
DESCRIZIONE			CODICE
BASKETBLACK FBBS			FBBS316L300FF__M__
			REV.
REV.	DESCRIZIONE REVISIONE	DATA REV.	REVISIONATO DA:
1	-	-	-
2	-	-	-
3	-	-	-
4	-	-	-
RIPRODUZIONE PROIBITA - TUTTI I DIRITTI RISERVATI AI SENSI DELLA LEGGE			SCALA 1:5

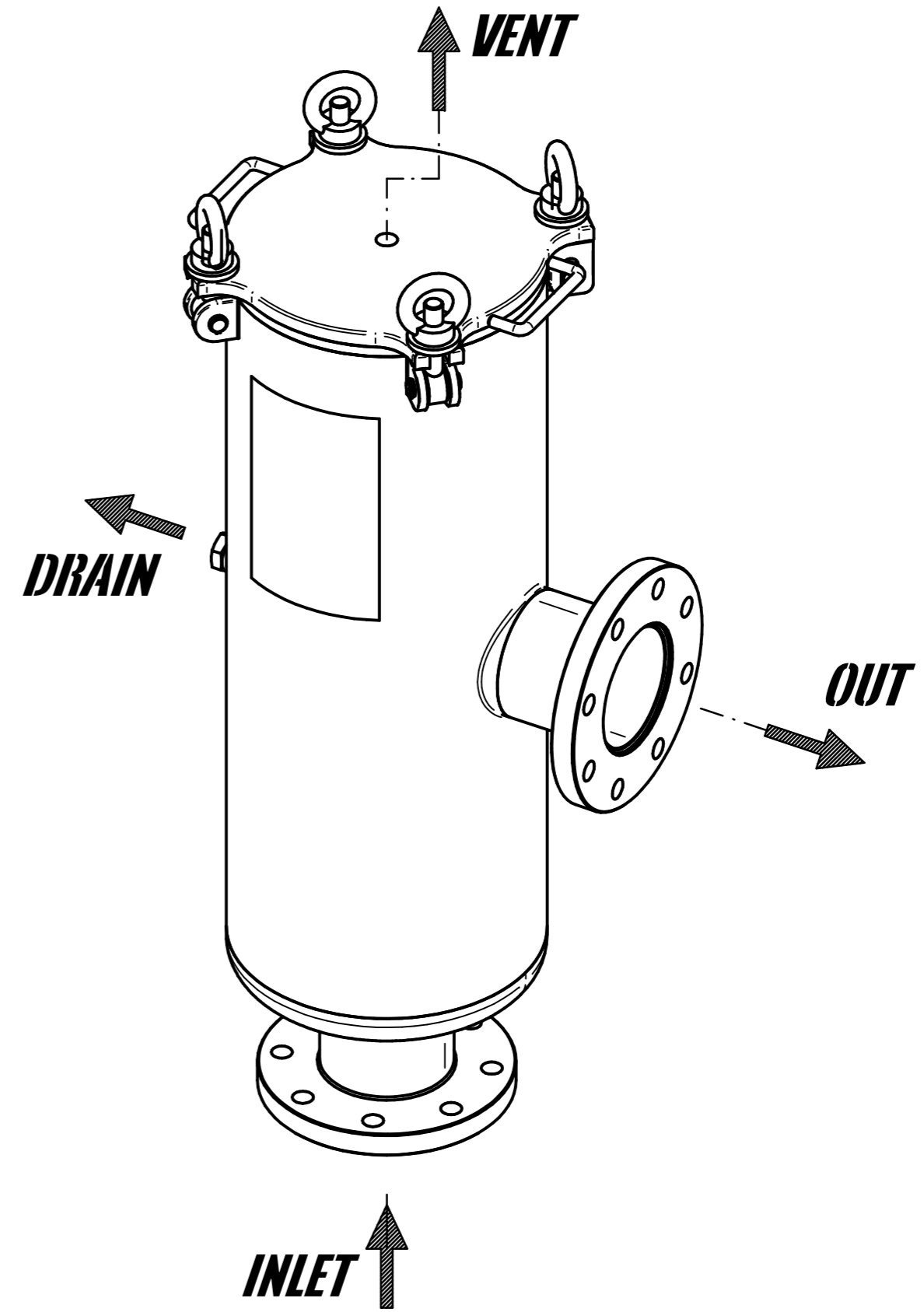
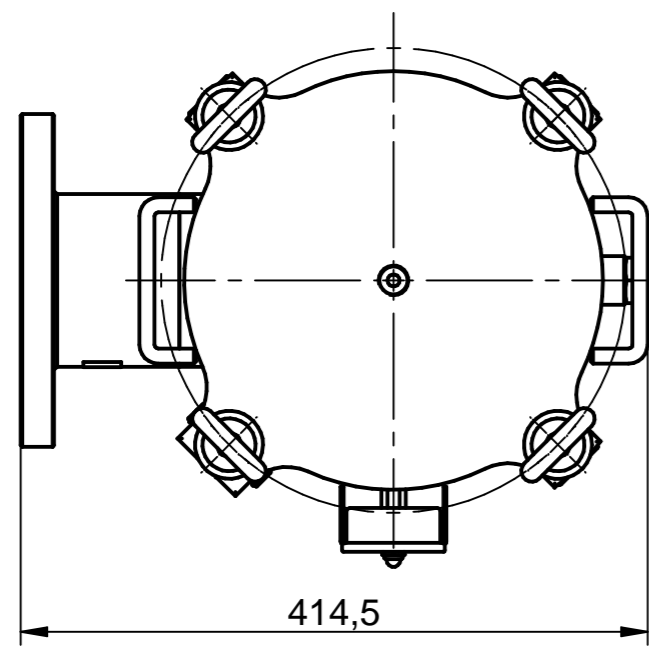
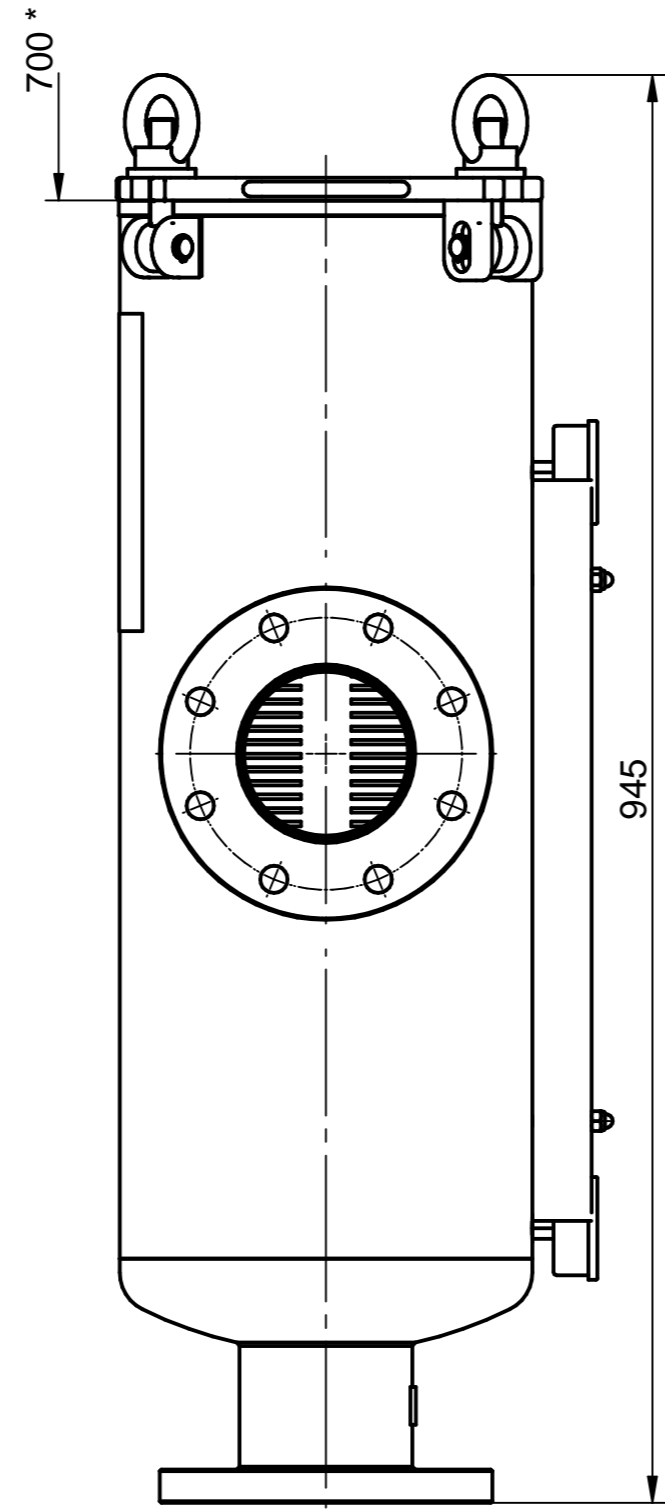
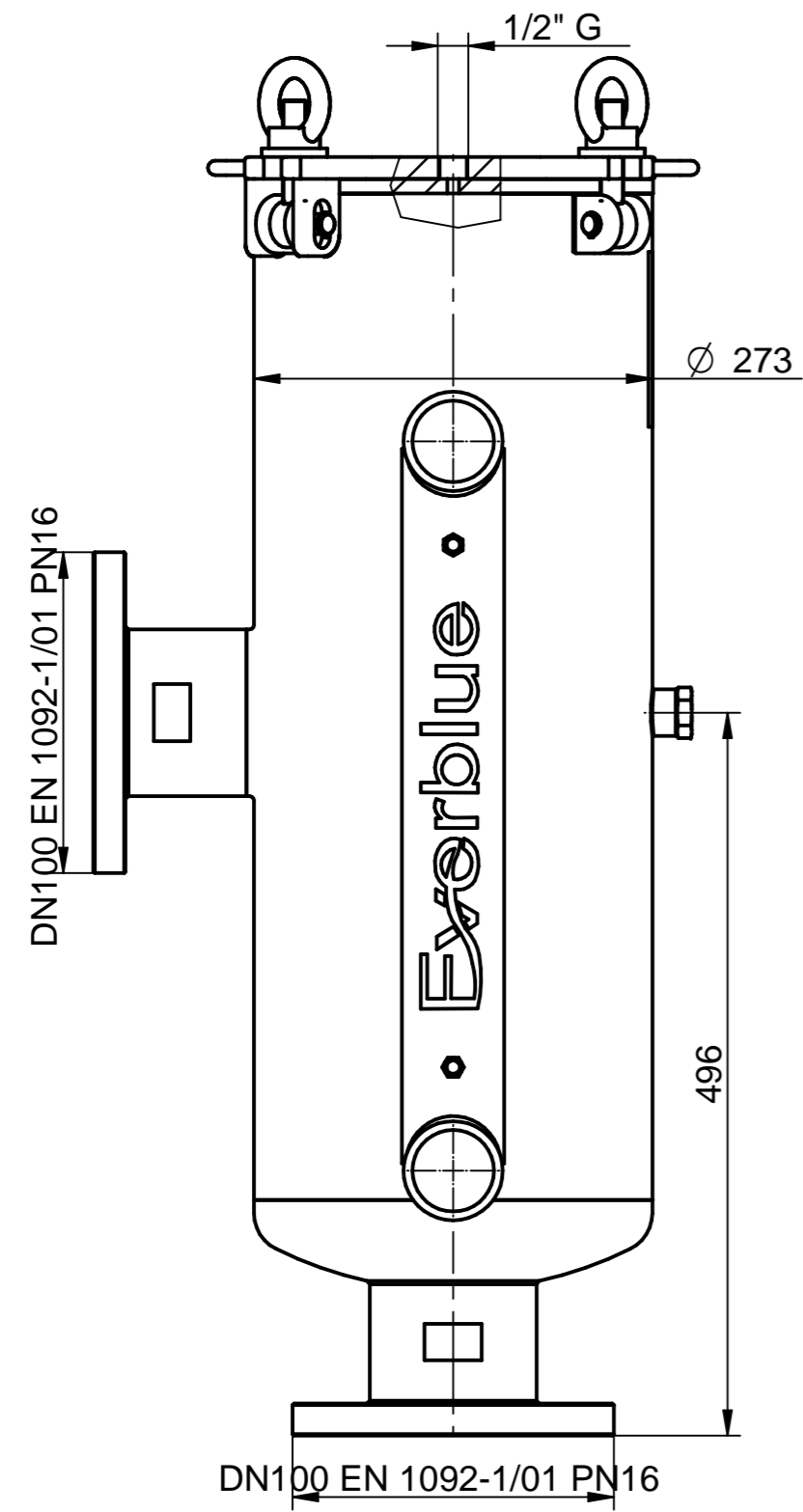

* DISTANZA MINIMA PER MANUTENZIONE
 * MINIMUM DISTANCE FOR MAINTENANCE

Dimensioni in mm.		Finitura superfici in Ra µm		TOLLERANZE GENERALI : UNI-EN 22768-mK UNI-EN 22768-c		RAGGI NON QUOTATI: R=0.3 SMUSSI NON QUOTATI: 0.3x45°	
MATERIALE : GREZZO : - FINITURA SUPERFICIALE : -				DISEGNATO DA : Tecnico DATA 14/11/2025		APPROVATO DA : - DATA : -	
DESCRIZIONE BASKETBLACK FBBS				CODICE FBBS316L400FF__ _M			
		REV.	DESCRIZIONE REVISIONE	DATA REV.	REVISIONATO DA:	SCALA 1:5	
		1	-	-	-		
		2	-	-	-		
		3	-	-	-		
		4	-	-	-		

RIPRODUZIONE PROIBITA - TUTTI I DIRITTI RISERVATI AI SENSI DELLA LEGGE

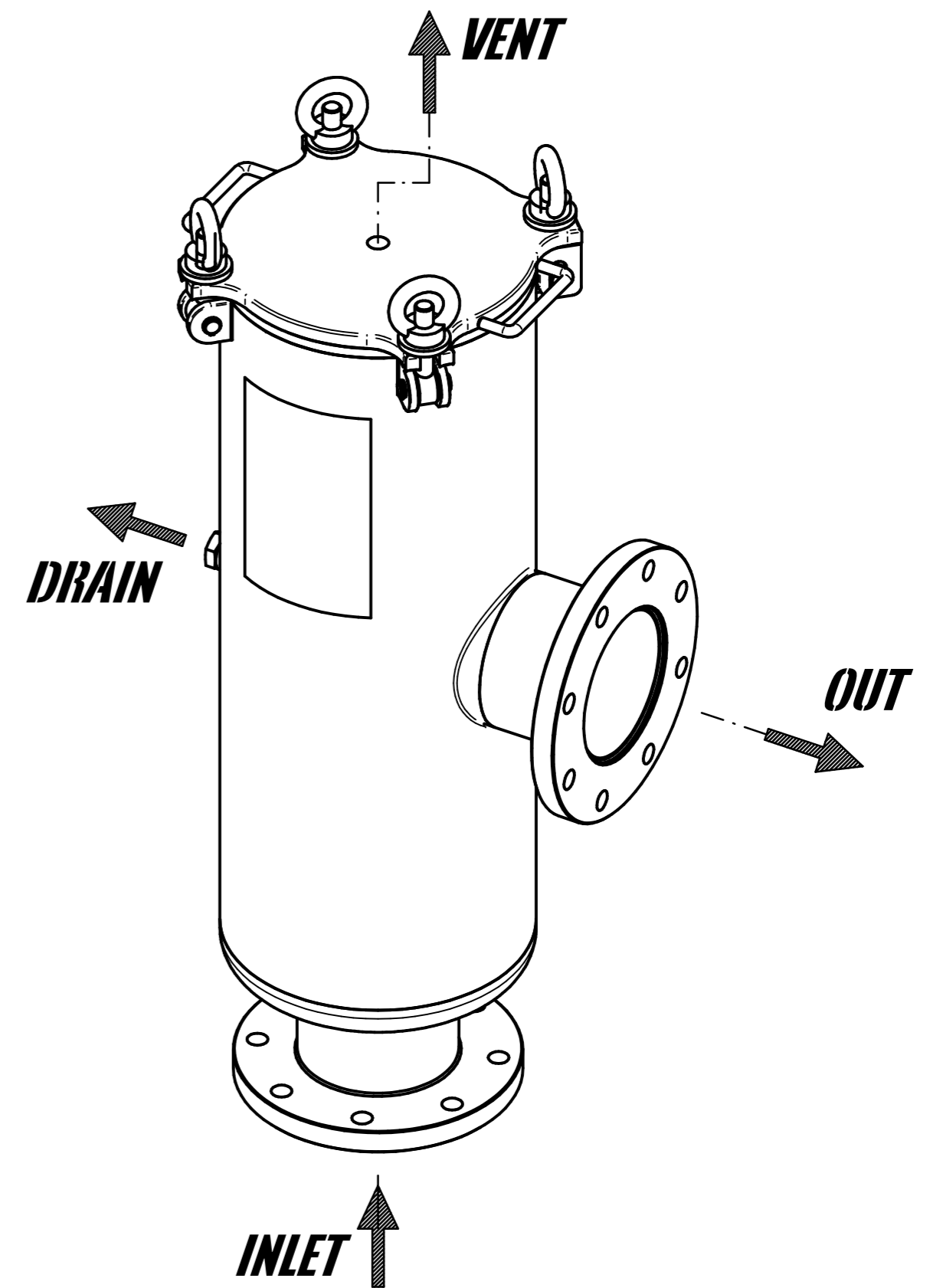
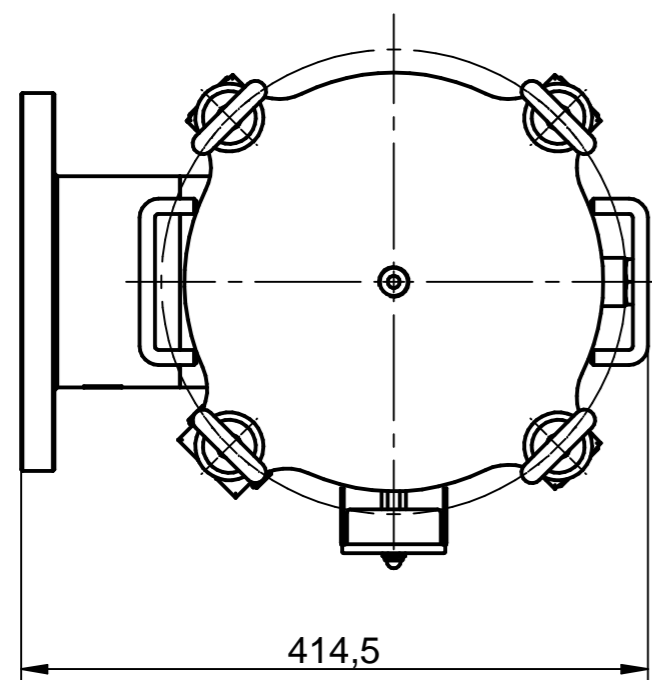
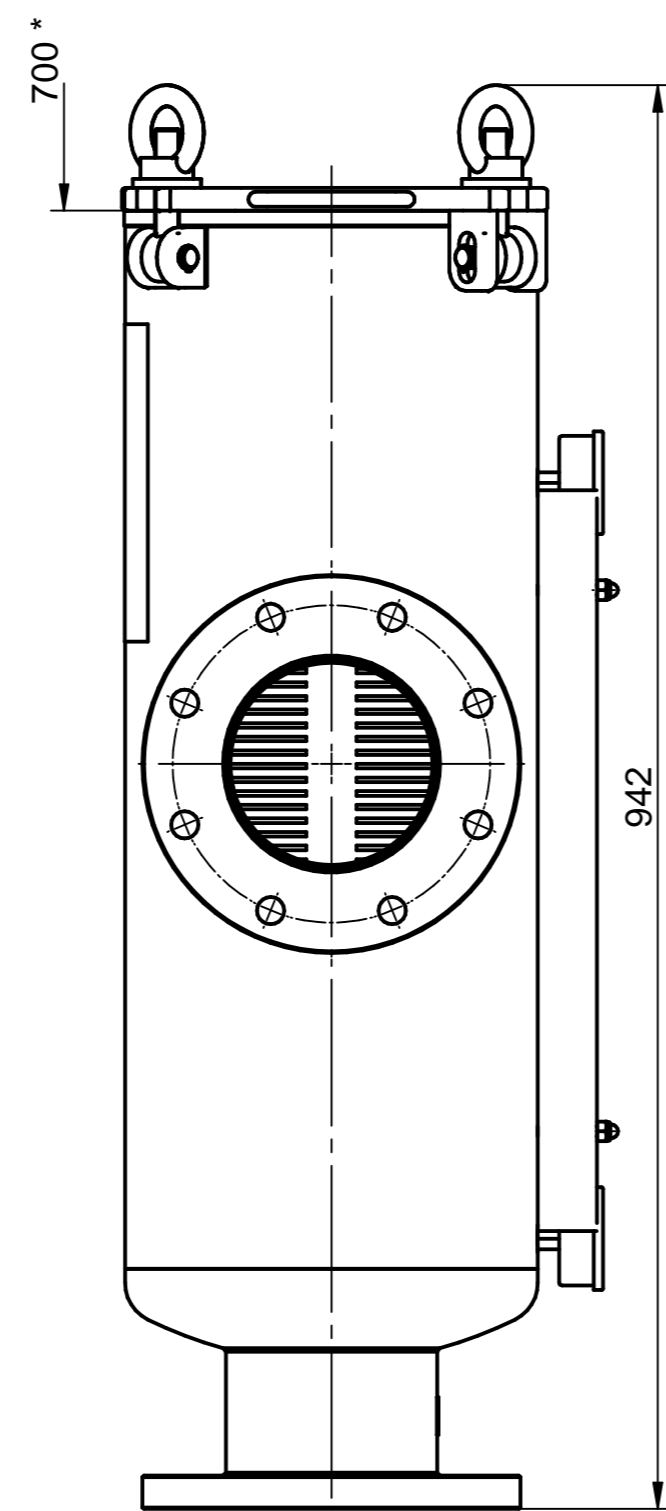
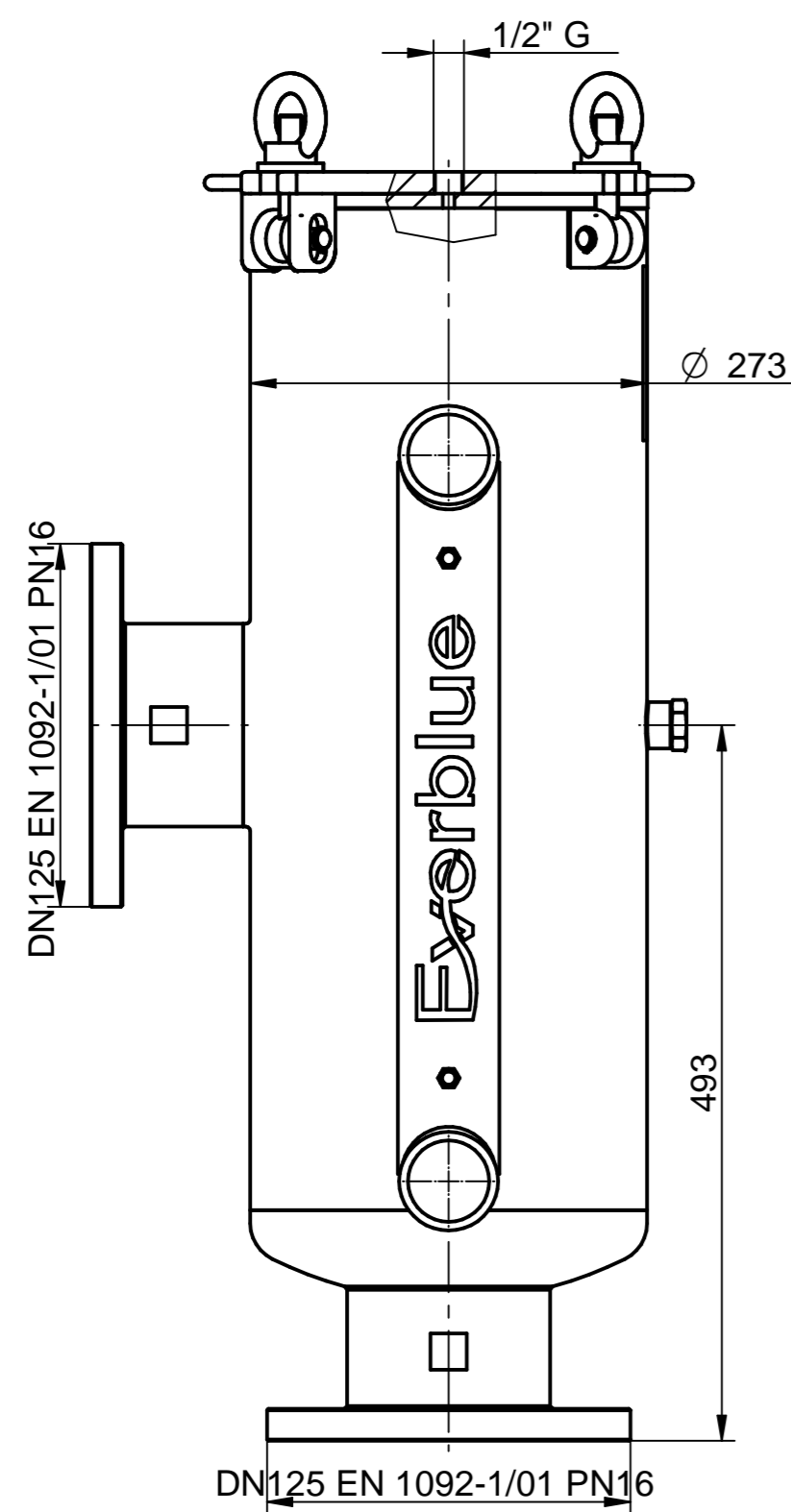

* DISTANZA MINIMA PER MANUTENZIONE
 * MINIMUM DISTANCE FOR MAINTENANCE

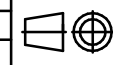
Dimensioni in mm.		Finitura superfici in Ra µm		TOLLERANZE GENERALI : UNI-EN 22768-mK UNI-EN 22768-c		RAGGI NON QUOTATI: R=0.3 SMUSSI NON QUOTATI: 0.3x45°	
MATERIALE : GREZZO : - FINITURA SUPERFICIALE : -				DISEGNATO DA : Tecnico DATA 14/11/2025		APPROVATO DA : - DATA : -	
DESCRIZIONE BASKETBLACK FBBS				CODICE FBBS316L500FF__ _M			
		REV.	DESCRIZIONE REVISIONE	DATA REV.	REVISIONATO DA:	SCALA 1:5	
		1	-	-	-		
		2	-	-	-		
		3	-	-	-		
		4	-	-	-		

RIPRODUZIONE PROIBITA - TUTTI I DIRITTI RISERVATI AI SENSI DELLA LEGGE

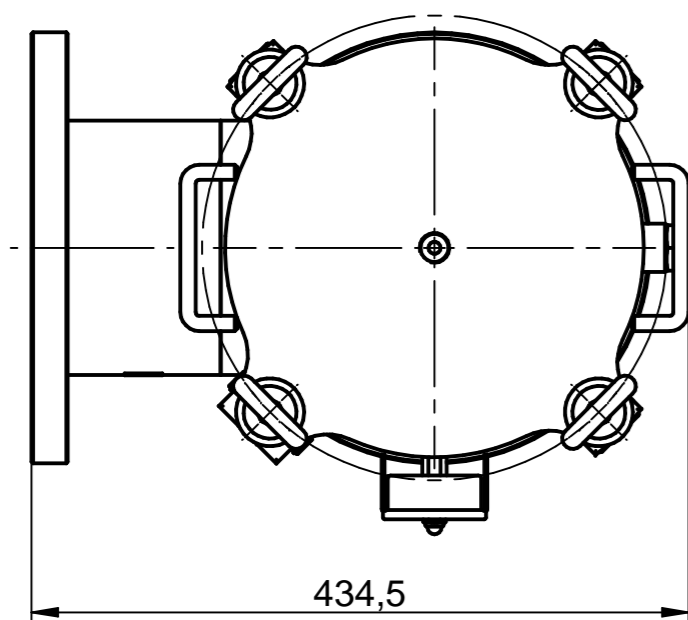
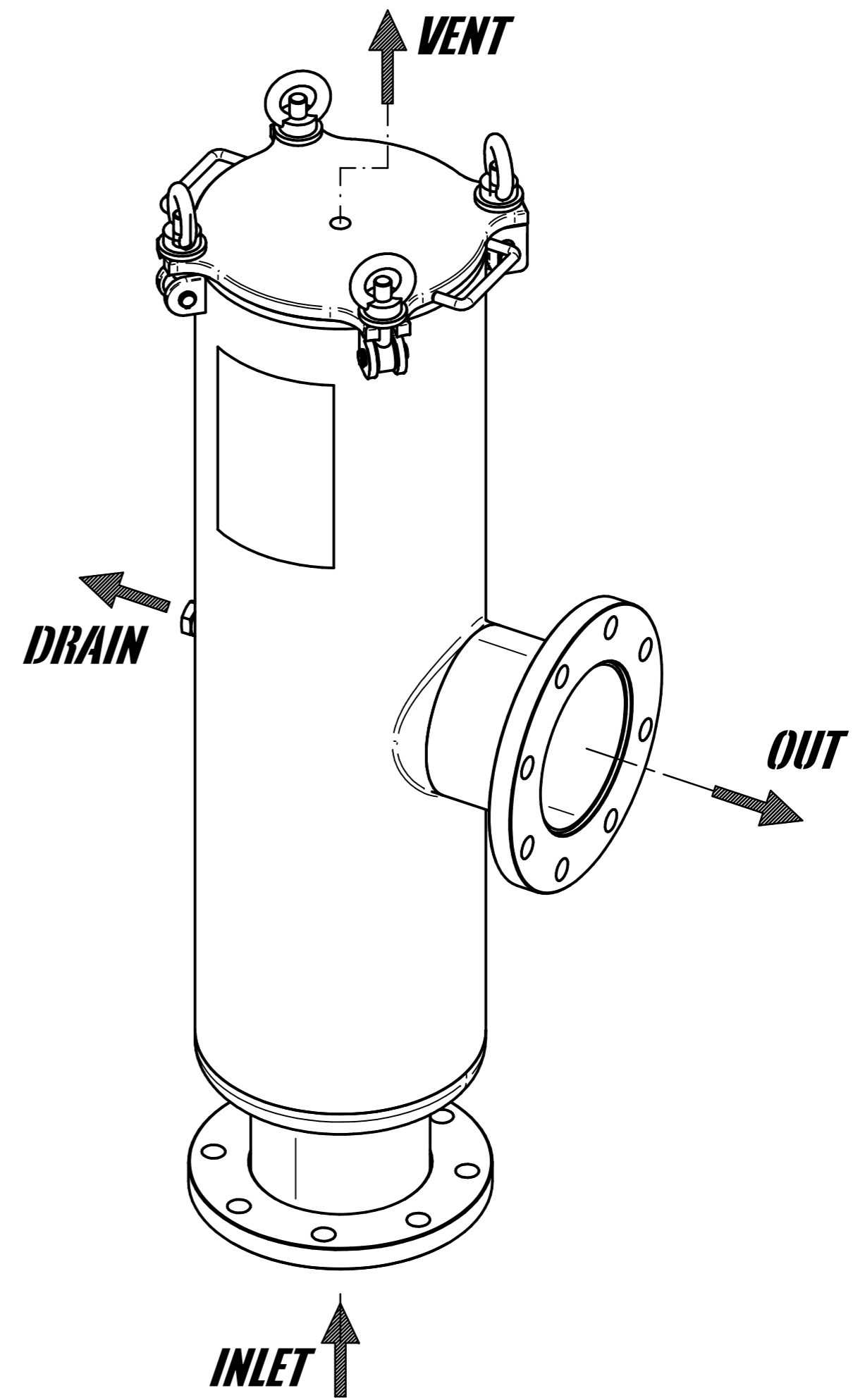
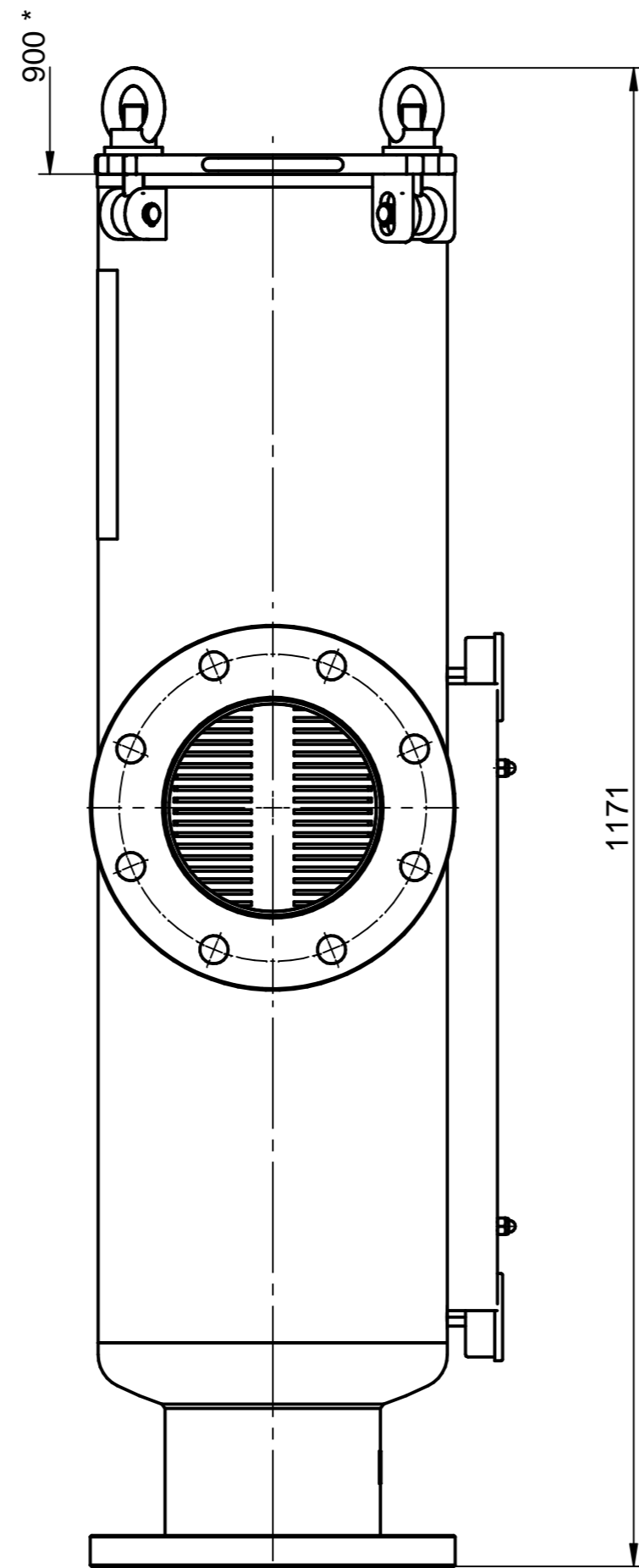
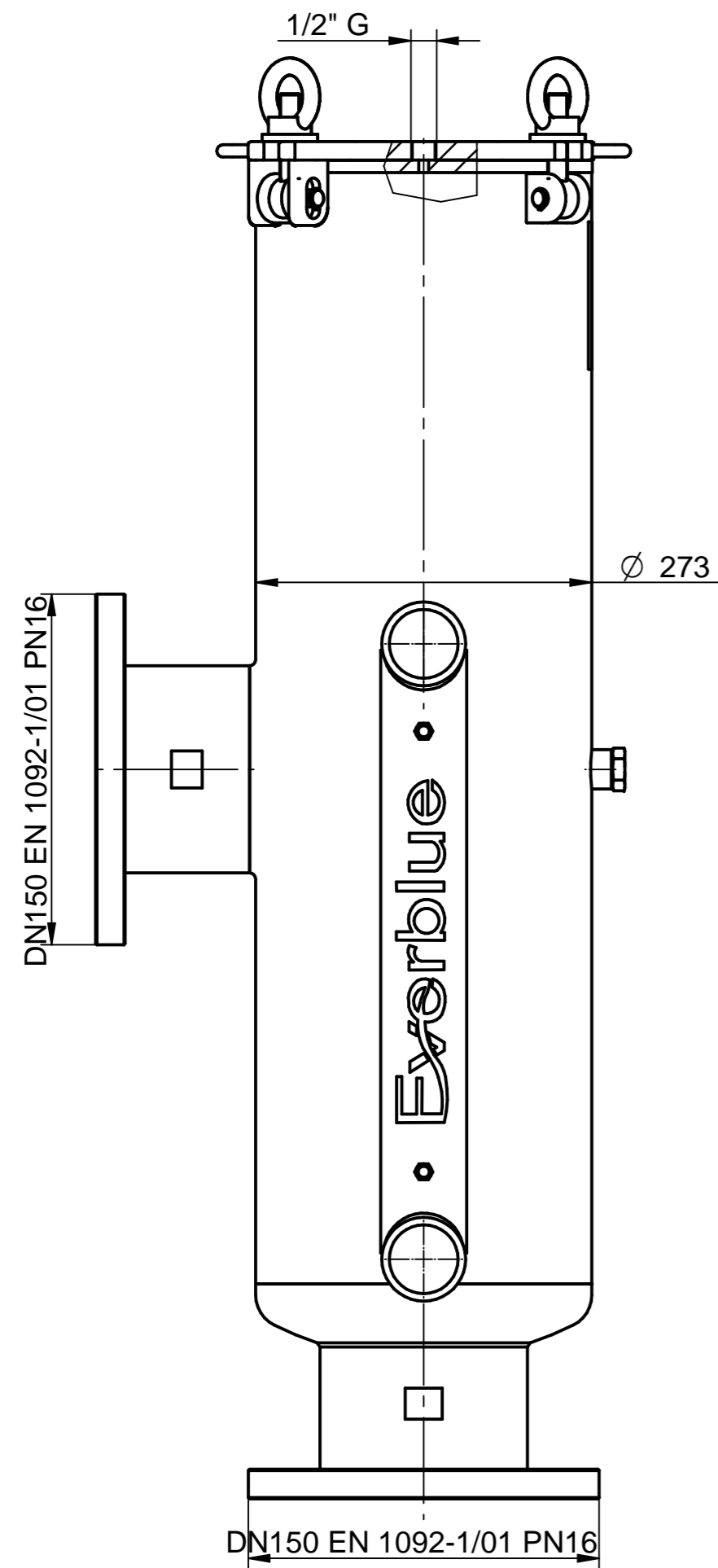

∴ DISTANZA MINIMA PER MANUTENZIONE
 ∴ MINIMUM DISTANCE FOR MAINTENANCE

Dimensioni in mm.	Finitura superfici in Ra µm	TOLLERANZE GENERALI : UNI-EN 22768-mK UNI-EN 22768-c	RAGGI NON QUOTATI: R=0.3 SMUSSI NON QUOTATI: 0.3x45°
MATERIALE :	GREZZO : -	DISEGNATO DA : Tecnico	APPROVATO DA : -
FINITURA SUPERFICIALE : -		DATA 14/11/2025	DATA : -
DESCRIZIONE BASKETBLACK FBBS		CODICE FBBS316L600FF__M	
		REV.	DESCRIZIONE REVISIONE
		1	-
		2	-
		3	-
		4	-
RIPRODUZIONE PROIBITA - TUTTI I DIRITTI RISERVATI AI SENSI DELLA LEGGE		DATA REV.	REVISIONATO DA:
		SCALA	1:5

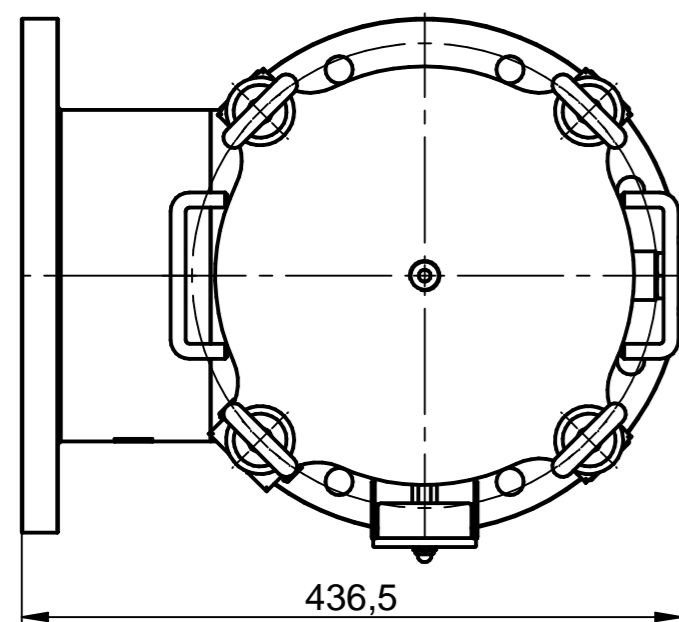
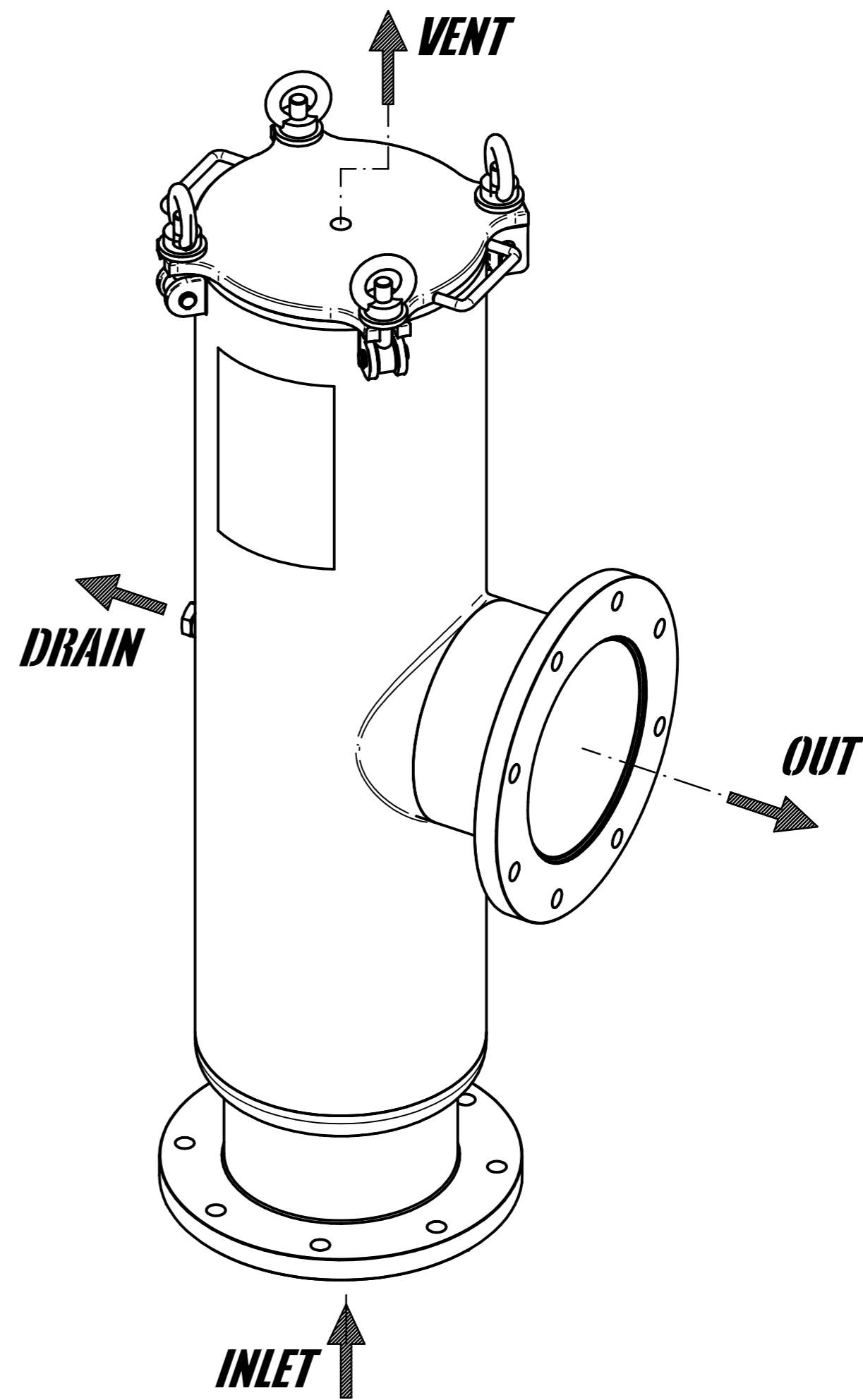
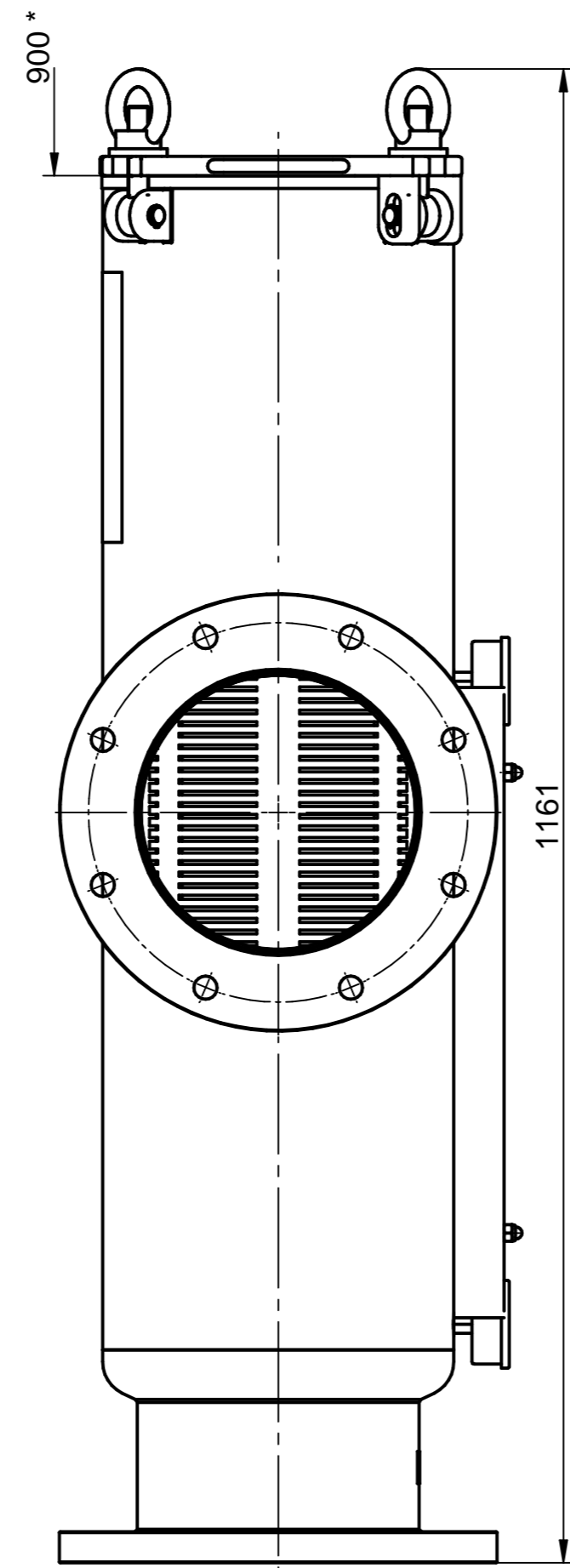
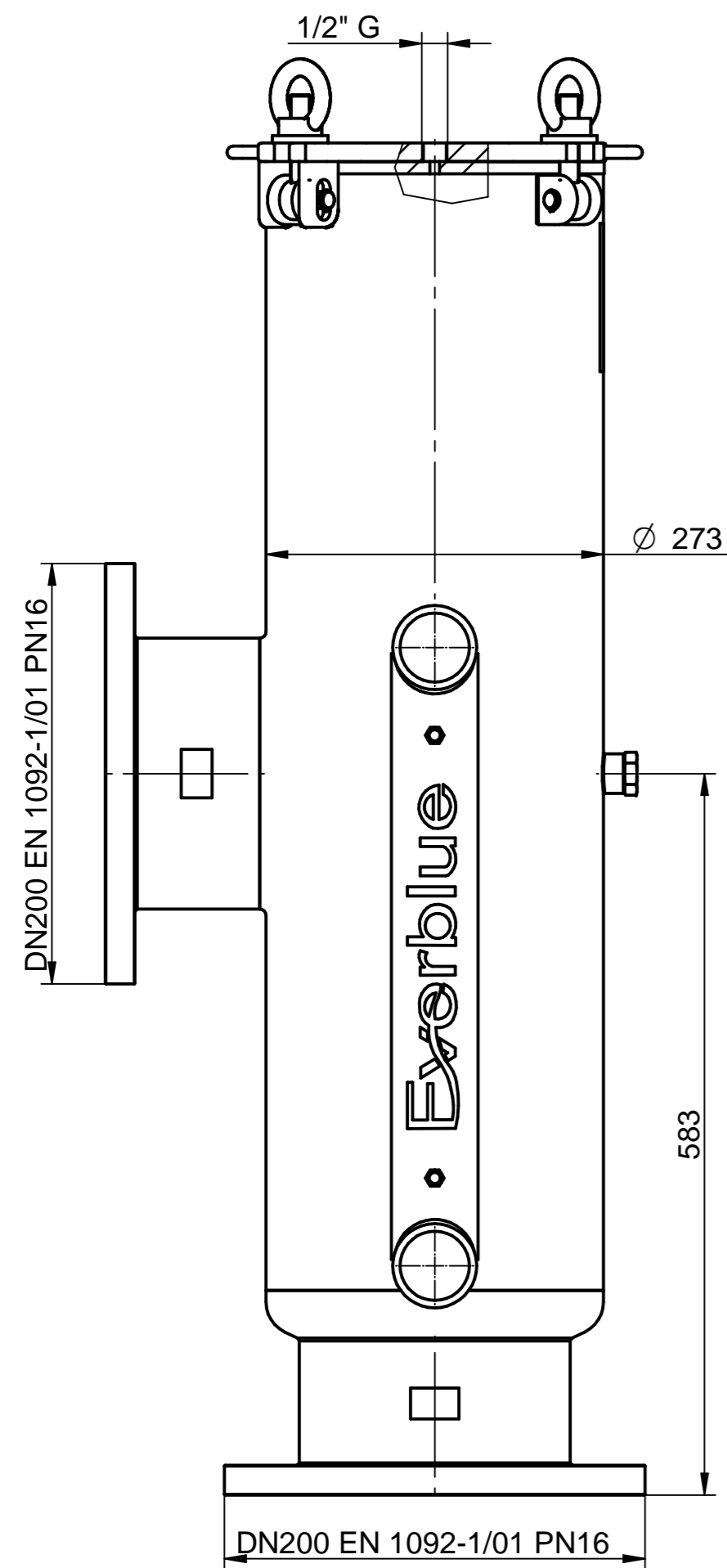

* DISTANZA MINIMA PER MANUTENZIONE
 * MINIMUM DISTANCE FOR MAINTENANCE

Dimensioni in mm.	Finitura superfici in Ra μ m	TOLLERANZE GENERALI : UNI-EN 22768-mK UNI-EN 22768-c	RAGGI NON QUOTATI: R=0.3 SMUSSI NON QUOTATI: 0.3x45°
MATERIALE : GREZZO : -	DISEGNATO DA : Technico		APPROVATO DA : -
FINITURA SUPERFICIALE : -	DATA 30/10/2025		DATA : -
DESCRIZIONE BASKETBLACK FBBS		CODICE FBBS316L800FF__M__	
		REV.	DESCRIZIONE REVISIONE
		1	-
		2	-
		3	-
		4	-
RIPRODUZIONE PROIBITA - TUTTI I DIRITTI RISERVATI AI SENSI DELLA LEGGE		DATA REV.	REVISIONATO DA:
		SCALA	1:5